

Annex A APPLICATION, FABRICATION, AND INSTALLATION

A.1 INTRODUCTION

The increasing use and application of high-pressure decorative laminates is testimony to their continued reputation for durable performance and appearance.

In recent years, the high-pressure decorative laminate industry has made many technical and aesthetic advances in its products. These are monitored and controlled by up-to-date test methods and improved manufacturing processes.

The aesthetic advances include new patterns and designs and decorative laminates that have sculptured three-dimensional surfaces, metal surfaces, and gloss. Some of these may not have the utilitarian latitude of service for horizontal applications that the regular surface finishes have and may be restricted for use (for example, vertical applications only). For recommendations on the use of a particular finish or surface the laminate manufacturer should be consulted.

By using the recommendations in this section as a starting point, users will find much to guide them in obtaining the most appropriate satisfactory installation. However, these recommendations are not intended to assume or replace the responsibility of the user to establish engineering design, practices, and procedures best suited to individual job conditions. This section will provide basic information on the fabrication and installation of decorative laminates and a better understanding of the product and its uses.

A.2 GENERAL DISCUSSION

High-pressure decorative laminates are used as surfacing material on counters, desk tops, cabinets, wall paneling, and furniture. The physical characteristics of the material should be considered in planning its fabrication and installation.

The properties of the finished laminate clad assembly will be influenced by:

- a. Laminate selection (grade, finish, color, and pattern).
- b. Adhesive.
- c. Substrate.
- d. Conditioning of the laminate and substrate.
- e. Fabrication techniques.
- f. Stress crack prevention.
- g. Balancing.
- h. Installation.

Like wood, a high-pressure decorative laminate has a grain direction, and its dimensional behavior is similar to that of wood (see Figure A-1). When humidity changes, the width of the laminate undergoes greater dimensional change than the length by a ratio of approximately 1.5 to 1. Dimensional change is a characteristic found in varying degrees in all cellulose type materials. As humidity decreases the laminate sheet contracts, and when the humidity increases the laminate sheet expands.

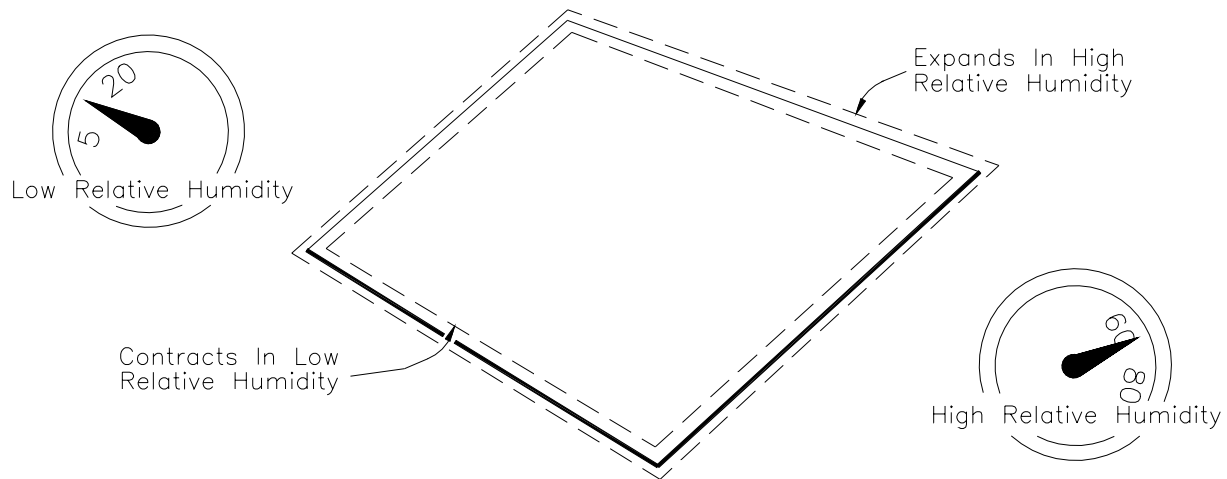

Figure A-1
HUMIDITY CHANGES

A.3 MATERIALS

Three basic materials are involved in the fabrication and installation of high-pressure decorative laminates. These are the laminate, the adhesive, and the substrate or supporting material.

A.3.1 High-Pressure Decorative Laminate

Laminates are classified in eight different types:

- a. General purpose (both horizontal and vertical grades).
- b. Postforming (both horizontal and vertical grades).
- c. Flame retardant.
- d. High wear.
- e. Specific purpose.
- f. Compact laminate.
- g. Cabinet liner.
- h. Backer.
- i. Other.

The different types were engineered to meet specific needs, based on performance, economy, and use. For example, thin general purpose laminates are suitable for vertical applications such as cabinet doors and panels. Postforming laminates allow simple bends which cover edges and eliminate the need for seams between vertical and horizontal planes such as those found on a sink top or cabinet door. The flame retardant type is designed for the specific fire-rated classification in accordance with local code requirements. The general purpose type laminate is the most widely used since it is suitable for many applications and should be considered first. If another type is required, the supplier of the laminate should be consulted for recommendations as to the type of laminate to be used.

Backer sheets are used on the back of panel-assemblies to protect the substrate from humidity changes and to reduce warpage.

See Figure A-2 for an illustration of some of these types.

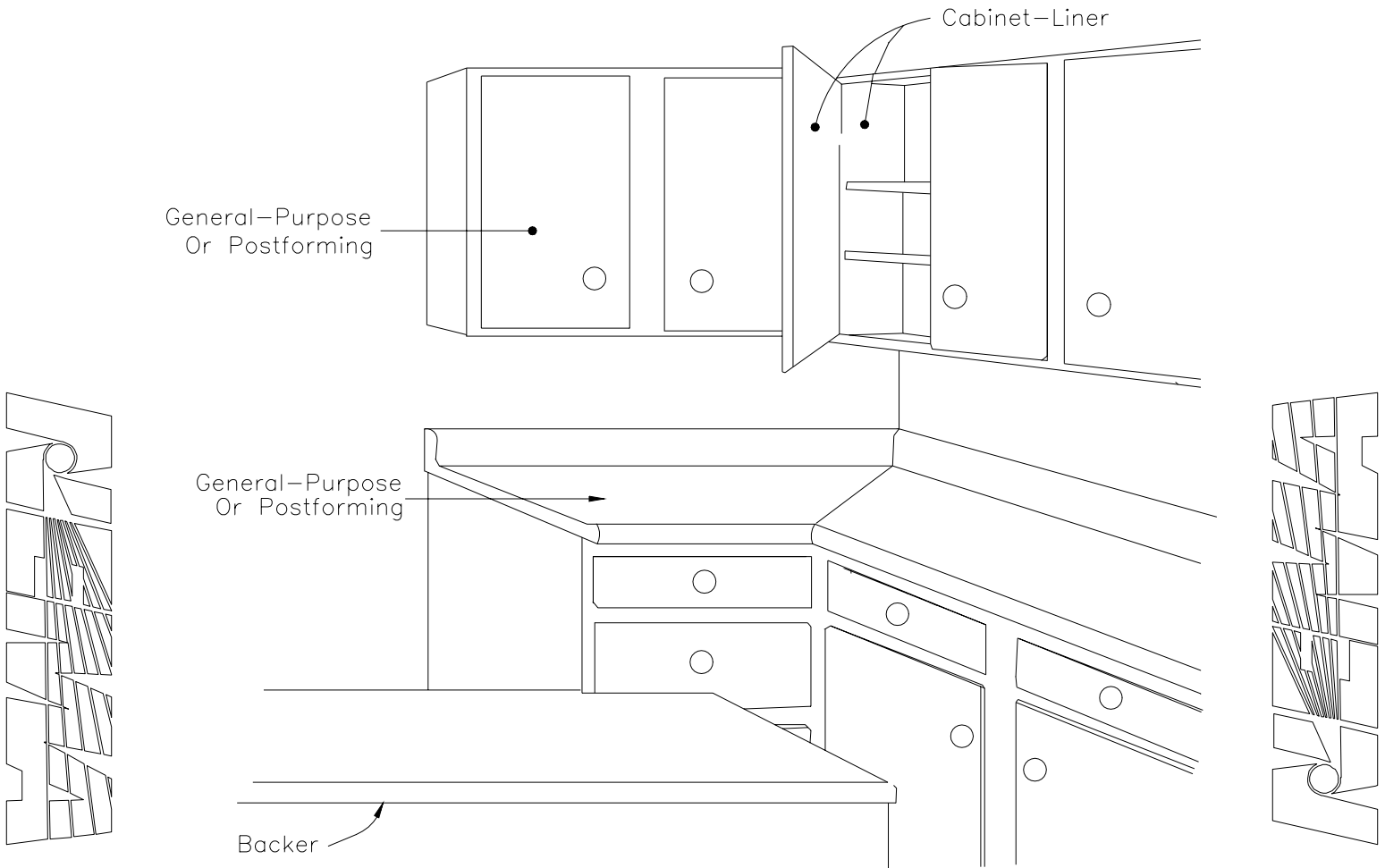

Figure A-2
TYPICAL TYPES OF LAMINATE USE

A.3.2 Adhesives

A variety of adhesives have been found satisfactory for bonding decorative laminates to core materials. The choice of adhesive is based upon the service for which the assembly is intended and upon the bonding facilities available. In all cases, the adhesive manufacturer's instructions for use should be followed closely. Contact adhesives do not restrict the movement of the laminate caused by varying humidity conditions to the same extent as thermosetting adhesives. This characteristic should be kept in mind when selecting the adhesive for the application.

The following information for the individual types of adhesives is intended only as a supplement to the manufacturer's instructions.

A.3.2.1 Contact Types

Contact adhesives may be used for bonding laminates to a variety of cores. They are particularly useful for application to metal or other impervious surfaces. There are two primary types of contacts; solvent-based and water-based. Water-based adhesives are not suitable for bonding laminates to steel or iron surfaces. The solvent or the water must be evaporated before satisfactory bonding can be accomplished.

Contact adhesives should be uniformly applied to both surfaces to be bonded by a brush, sprayer, or paint roller. Brush application is the least desirable method because of the difficulty in obtaining uniform application.

These adhesives have high immediate bond strength, and once contact has been made, the components cannot be moved.

A.3.2.2 Polyvinyl Acetate Types (White Glue)

Polyvinyl acetate (PVAc) emulsion adhesives may be used for bonding laminates to wood substrates where resistance to moisture and high heat are not required in the application (e.g., furniture, kitchen cabinets, and office partitions). They may be both room temperature and hot pressed setting adhesives requiring only that the water in the emulsion be absorbed by the components. Catalyzed PVAc offers improved moisture and heat resistance.

A.3.2.3 Thermosetting Types

- a. Urea-formaldehyde adhesives are satisfactory for most applications. They can be used for room temperature bonding or for "hot" bonding. Hot bonding may tend to increase panel warpage, and a backer laminate should be used to reduce warpage. When hot bonding, the temperature should not exceed 85°C (185°F) for best results.
- b. Resorcinol and phenol-resorcinol adhesives are recommended for use when moisture resistance and heat resistance are required. They may be used in either hot-pressing or room temperature bonding. Phenol-resorcinols are sometimes used as a pre-impregnated adhesive sheet in a hot-pressing operation. Resorcinols can be used with fire rated laminates to meet specific fire rated classifications.
- c. Epoxy adhesives are liquids with no volatile components. They have good gap-filling and low shrinkage properties and are used mainly for bonding laminates to impervious cores such as steel. They should be catalyzed for use in either hot or room temperature bonding operations.

A.3.2.4 Hot Melt Types

Hot melt adhesives are suitable for use only in edge banding operations because of their low heat resistance. It is recommended that the particular grade adhesive chosen should have a minimum softening point of 65°C (150°F). Most hot melt manufacturers recommend a primer be applied to the back of the high-pressure decorative laminate prior to bonding. The adhesive manufacturers' recommendation for environmental conditions during application should be closely followed due to the application temperature sensitivity of the adhesive.

A.3.2.5 Urethane Types

Urethane adhesives are liquids with 100% solids and no volatile components. They have good gap-filling and low shrinkage properties and are used mainly for bonding laminates to impervious cores such as steel. There are various hot-melt urethane type adhesives which are utilized for bonding to medium density fiberboard. These adhesives may be either moisture cured or catalyzed and may be pressed in either hot or room temperature bonding operations.

A.3.3 Substrate

Good quality particleboard and medium or high density fiberboards are satisfactory for use as substrates since they supply the degree of rigidity needed to support the laminate and offer a suitable face for bonding. Many particleboards are engineered for flatness. These boards have, for example, strata of varying chip size with the finer chips at the surface. Their dimensional movement is similar to that of high-pressure decorative laminate.

The face of the substrate should be sanded smooth and be free from grease, wax, dust, or other contaminants that would interfere with adhesion. It should also be free of chips or other foreign matter that might show through the decorative surface after bonding.

Plywood, steel, aluminum, fiber reinforced plastic (FRP) may be used in some applications, but their dimensional movement is significantly different than high-pressure decorative laminate. This may result in potential panel warpage, stress cracking, and open seams.

It should be noted that certain properties of the assembly are influenced by the substrate. Plaster board, gypsum board, plaster, concrete, and similar materials are not recommended because their internal bond strength is not sufficient for this application.

A.3.4 Factors Affecting Bonded Assemblies

Some factors that affect bonding are shown in Figure A-3. Causes and recommendations for avoiding failures are:

- a. Insufficient amount of adhesive on either or both of the surfaces to be bonded—When ready for bonding, the spread film of most contact adhesives will exhibit a uniform semi-gloss appearance over the entire surface of the materials to be bonded. Marked variation in appearance will generally indicate an improper or non-uniform adhesive spread. The substrate can generally be seen more readily through those areas where insufficient adhesive has been applied. If this occurs, recoating the surfaces should achieve a uniform coating. Double coating the edges with adhesive is advisable because of the higher porosity of the substrate edge.
- b. Insufficient bonding pressure—To ensure intimate contact necessary for an adequate bond, sufficient pressure should be applied over the entire area using as much pressure as possible without damaging the assembly. Pinch rollers (rotary press) and heavy weighted rollers are ideal. Hand pressure rolling is adequate providing the operator exerts maximum pressure by means of a two-handled or single long handled roller. The rollers should be of steel or hard solid rubber (50–80 durometer) and not over 75 mm (3 in.) wide. Hand rolling should be done from the center to the edges to ensure the removal of all air bubbles. The edges should be rolled twice.
- c. Bonding when adhesive surfaces are over-dry or under-dry—Care should be taken to follow the manufacturer's recommendations concerning the allowable tack range of the adhesive. If assembly is made before the adhesive is dry or after the allowable open time is exceeded an unsatisfactory bond may result.
- d. Bonding of surfaces under 21°C (70°F)—Unless otherwise indicated by the manufacturer, the temperature of the gluing area and all materials should be 21°C (70°F) or above.
- e. Bonding of surfaces when humidity is too high—Experience has shown that when the relative humidity is above 80 percent at temperatures of 21°C (70°F) or lower, moisture may condense on the surface during drying (known as "blushing") and will prevent an acceptable bond. Hot spray or forced air drying may be used to help prevent this condition.
- f. Improperly prepared or dirty gluing surfaces—The surfaces should be clean, dry, and free of oils or other contaminants, such as dust, loose paint particles, and so forth. The adhesive film should have full contact with the surface to which it is applied in order to give maximum adhesion.
- g. Adhesive not agitated or stirred thoroughly—The adhesive should always be stirred or agitated before use. This is particularly necessary with large containers.
- h. Field bonding of oversized sheets—It is recommended that the maximum sheet size used for vertical field application be limited to 610 x 2440 mm (2 x 8 ft.). If larger panels are required, these should be fabricated in the shop.

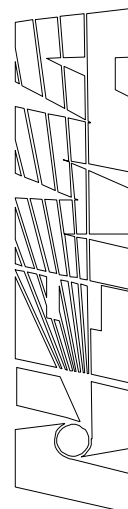
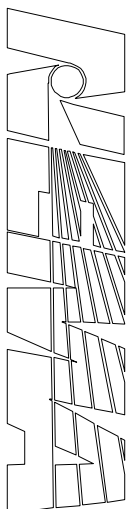

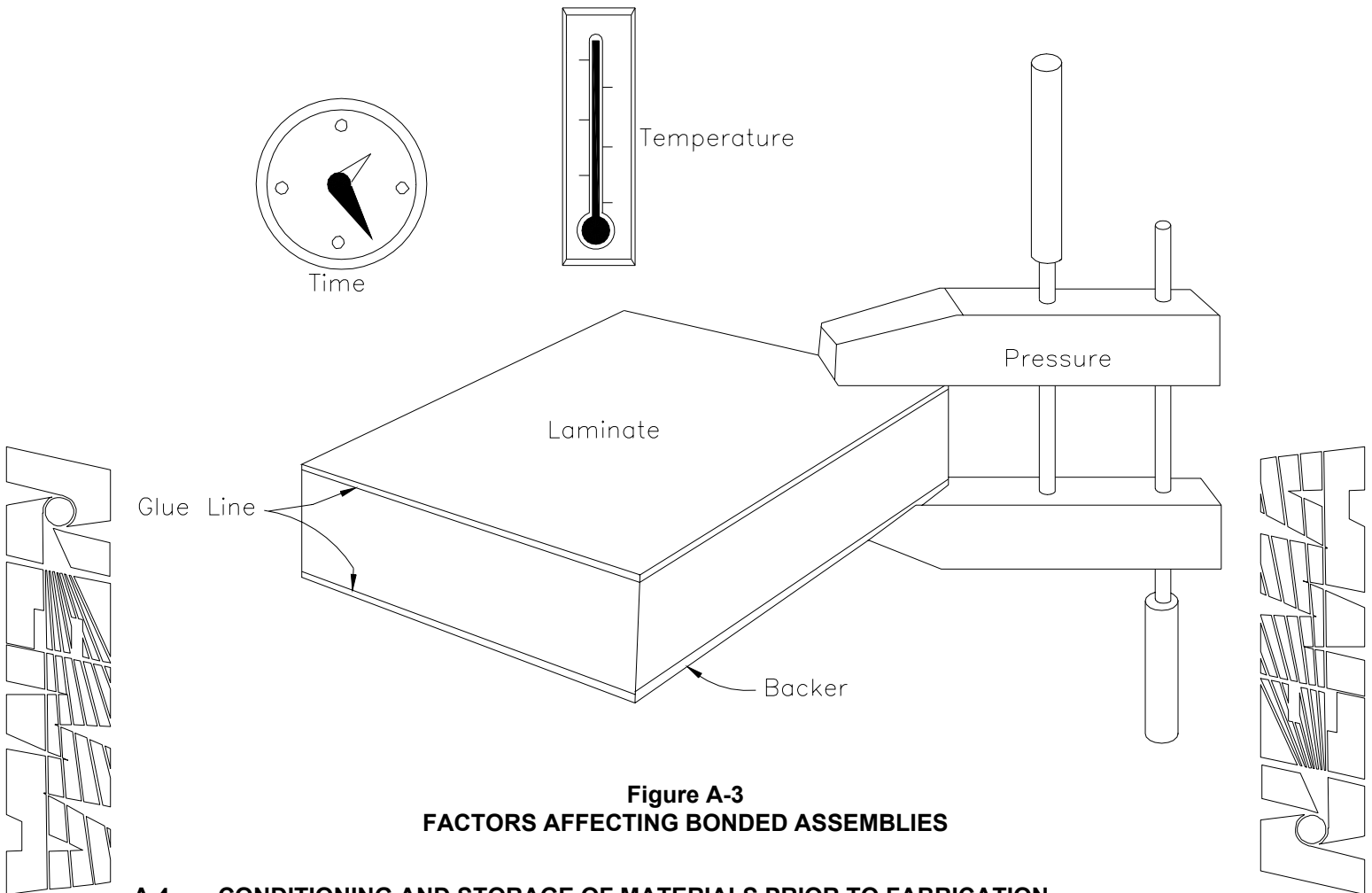

Figure A-3
FACTORS AFFECTING BONDED ASSEMBLIES

A.4 CONDITIONING AND STORAGE OF MATERIALS PRIOR TO FABRICATION

Materials should be properly conditioned before they are used. Conditioning should make allowances for the geographical location in which fabrication or installation takes place. For example, end products which are produced and used in the Southeastern United States are not as susceptible to shrinkage of the laminate with its attendant problems, as are articles used in northern climates. This is due to the fact that in the Southeast, the average yearly humidity is higher and the temperature does not vary as widely. Similarly, installations in the Southwest, which normally has low humidity, are not as likely to be affected by changes in the length and width of the laminate after fabrication. In these areas, normal conditioning of the component parts for 48 hr prior to fabrication at the prevailing climatic conditions is usually sufficient for the satisfactory fabrication and installation.

However, end products are now frequently fabricated in one area of the country and marketed in a distant area. For example, a wardrobe may be fabricated in a location where temperature and humidity are both high and then be shipped into an area where they are both low. The laminate will tend to reach moisture equilibrium with the new environment and shrink. In such cases, it is advisable to dry the components before fabrication of the end product, and the use of a thermosetting adhesive is highly recommended.

Allow high-pressure decorative laminate and the substrate to acclimate for at least 48 hr at the same ambient conditions. Optimum conditions are approximately 23°C (73°F) and a relative humidity of 45% to 55%. Provision should be made for the circulation of air around the components.

Laminate sheets should be stored horizontally with the top sheet turned face down and a caul board placed on top to protect the material from possible damage and reduce the chance of warpage. Warped laminate sheets can be used unless the warp is so great that they cannot be properly fed through glue spreading or bonding equipment. Warp in the laminate sheet prior to bonding is not a cause of warp in the finished panel.

Stored laminate stock should be rotated such that older sheets will be used first. Laminate sheets should be protected from moisture, and should never be stored in contact with the floor or outside wall.

Always carry laminate sheets vertically. Handle full size sheets carefully to avoid breakage or injury. It is recommended that two people carry full size sheets. Be careful when moving sheets so as not to strike them against anything that could damage the decorative surface or the edges. Always lift sheets from one point to another, never slide sheets on their decorative surface.

A.5 FABRICATION TOOLING

The proper types of tools for fabricating decorative laminates may be obtained from many local tool suppliers. The following information is intended only as a supplement to their recommendations.

A.5.1 Sawing

To avoid chipping, it is important that the saw blade teeth cut into the decorative face.

A.5.1.1 Band Sawing

A band saw is recommended for curved or straight cuts when smooth edges or close tolerances are not required. For smooth edges on curved cuts, the part should be cut oversized and finished by routing, filing, or sanding.

A woodworking or metal cutting band saw blade may be used. Nineteen to 20 gauge carbon steel blades or hardened steel blades with soft backs should be used, with teeth ranging from 16 to 18 points per inch. Contour cutting requires a blade width of 6.35 to 12.70 mm (1/4 to 1/2 in.).

Straight cutting requires a blade width of 25.4 to 44.5 mm (1 to 1-3/4 in.). The teeth should have a medium set for straight cuts and a heavy set for contour cuts. The amount of set depends upon the radius of the cut required. The teeth should be kept sharp at all times. Adjust saw speed to maintain 1524 to 2438 surface m (5000 to 8000 surface ft) per minute, feeding the work into the blade at a rate only as fast as it will cut without forcing the saw.

A.5.1.2 Circular Sawing

- a. Floor or bench saws have been shown to be satisfactory. Material should be supported near the point of blade contact to avoid vibration that causes chipping. A triple chip grind tooth configuration is recommended for blades. In general, the blades illustrated in Figure A-4 and meeting the conditions of Table A-1 have been found to be satisfactory. Both tungsten carbide and diamond tip blades have shown to be excellent tools for sawing high-pressure decorative laminate.
- b. Powered circular hand saws with 60 carbide tipped teeth may be used for rough cutting. If used, the teeth should cut into the decorative face of the laminate in order to avoid excessive chipping. This means the laminate should be cut in the face-down position.

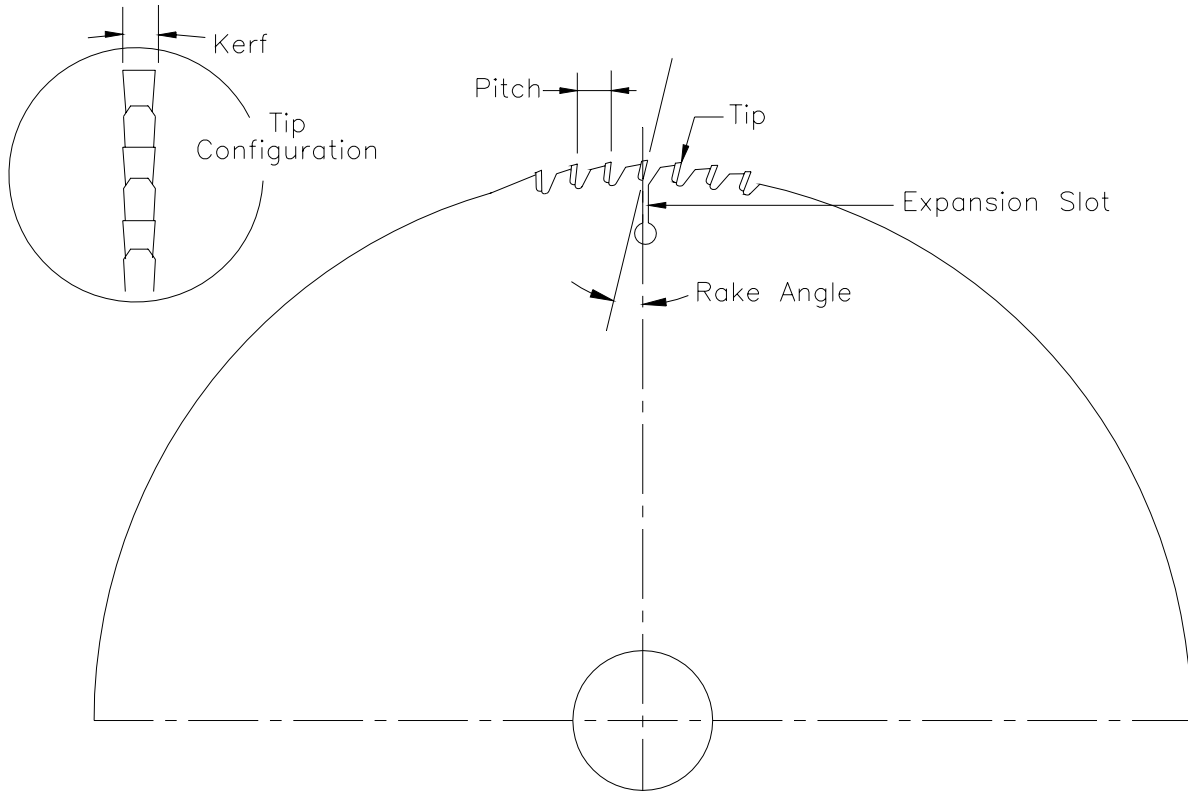

**Figure A-4
SAW BLADES**

**Table A-1
TYPICAL BLADES**

Parameter	Unbonded Laminate	Bonded Panel—19 mm (3/4 in)
Diameter	203.2 to 355.6 mm (8 to 14 in.)	203.2 to 355.6 mm (8 to 14 in.)
Speed per minute	2438 to 4572 m (8000 to 15000 ft.)	2438 to 4572 m (8000 to 15000 ft.)
Pitch	10.59 mm or less (0.417 in. or less)	13.21 mm or less (0.520 in. or less)
Rake angle	10° to 15°	10° to 15°
Kerf	1.74 to 2.79 mm (0.068 to 0.110 in.)	2.39 to 3.43 mm (0.094 to 0.135 in.)

A.5.2 Routing

Routing may be done with electric or air powered routers. Cutters should be carbide tipped. The speeds recommended are the same as those used in standard woodworking practices. Router speed should be 16000 to 22000 rpm. It is important to use a router having adequate horsepower to maintain cutting speeds (based on the type and amount of material to be cut). For special edge trimming, very high-speed routers are available which produce smooth-edge chip-free work.

Sharpness of the router cutters should be maintained.

A.5.3 Sanding

Belt sanders may be used to flush the self-edge before the laminate top is applied. However, care should be taken to direct the sanding operation away from or parallel to the decorative surface.

A.5.4 Drilling

Decorative laminates can be drilled using an electric drill with the more common types of drill bits (e.g. high speed steel, twist drill, forstener, or brad point bits). Large holes can be drilled using a hole saw, flycutter, or can be plunge cut with a router and template. For machine drilling (drill press) a high speed straight shank twist drill is satisfactory.

To prevent stress cracking, the drill diameter should always be 0.05 mm (0.002 inch) larger than the specified diameter of the hole. Regardless of the diameter of the hole, all material being drilled should be backed up with wood to prevent breakout at the bottom of the drilled hole.

A.6 GENERAL RULES FOR FABRICATION AND INSTALLATION

A.6.1 Fabrication in the Shop

Good fabrication techniques indicate the following basic guidelines:

- a. Storage conditions—A primary consideration of the fabricator should be the proper storage and conditioning of component materials. Both the laminate and the substrate should be conditioned for a minimum of 48 hours at a temperature between 21° to 24°C (70° to 75°F) and a relative humidity of 45% to 55% (see Figure A-5) prior to bonding.

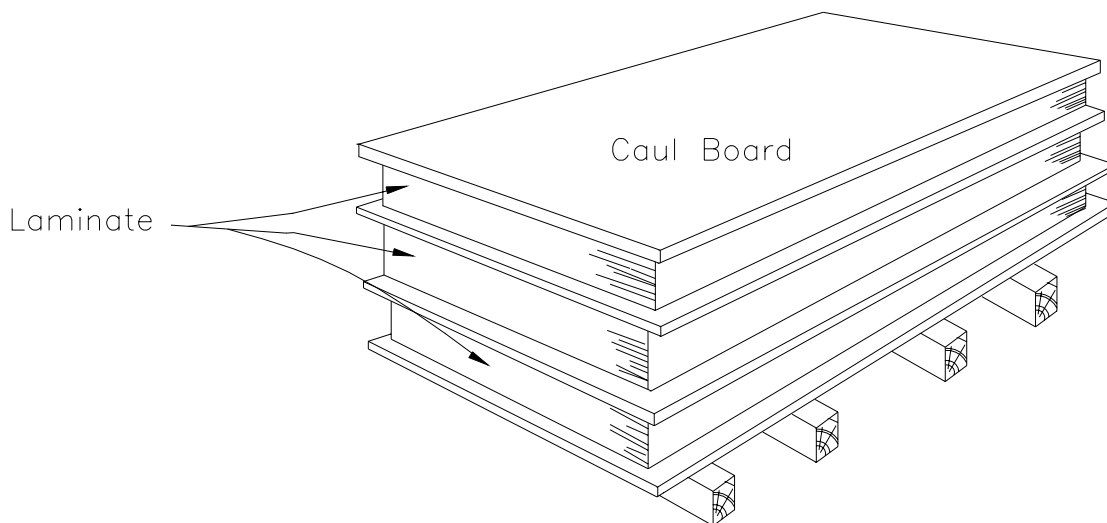

Figure A-5
CONDITIONING OF LAMINATE

- b. Control of the glue line—Control of the glue line is another consideration, and the thickness and uniformity of spread should be given constant attention. The substrate (and, in the case of

contact adhesives, the laminate) should be coated with adhesive over the entire area where contact will be made. Spot bonding should never be used.

c. Adhesives—Specific conditions are recommended by each adhesive manufacturer and these conditions should be followed.

- 1) Contact—Contact adhesives are widely used in the laminate industry. They require no expensive press, and even large pieces can be field applied. Contact adhesives can be applied by brush, roller, hand spray, or automated spray. They are ideal for postforming since they are heat reactivated, and since they are relatively water resistant, are good for countertop applications. Flammable, non-flammable, and water base formulations are available. Contact adhesives are good for laminating nonporous surfaces. Drawbacks of contact adhesive in comparison to many other types of adhesives include lower heat resistance, reduced resistance to stress crack and shrinkage due to their elastomeric nature, thickness of glue line, and toxic and/or flammable vapors.

It is important that all surfaces to be bonded are clean, dry, and free of dust, oil, and other foreign matter. The work area, substrate, laminate, and adhesive should be maintained at 21°C (70°F) or warmer.

The substrate and laminate should be uniformly coated with adhesive over the entire area where bonding contact will be made. Spot bonding should never be used. Drying time will vary depending on temperature and humidity. The adhesive is ready to bond when it will not transfer to smooth kraft paper in a touch test. Forced drying may be used to speed the process or overcome fluctuations in ambient temperature or humidity. Forced drying may be necessary when bonding to metal or other nonporous materials. To assemble, prealign or index the surfaces to be bonded. Indexing sticks will prevent contact of the adhesive surfaces until proper alignment is achieved. Once contact is made, ample pressure must be applied to insure a strong bond. A pinch roller is preferred, with pressure between 0.90 and 1.35 kg per linear millimeter (50 and 75 lb. per linear in.), but pressure may also be applied with a “J” roller (see Figure A-6). Refer to Section A.3.4 for more information on bond pressures.

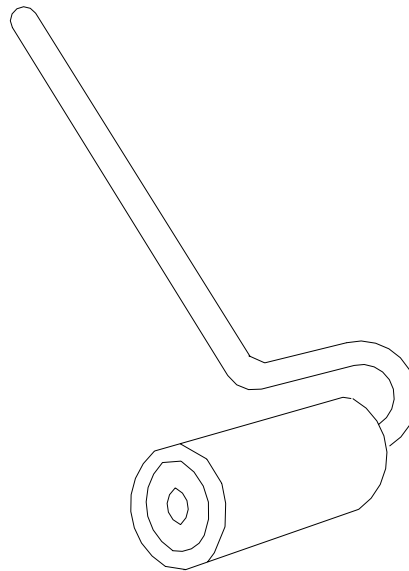
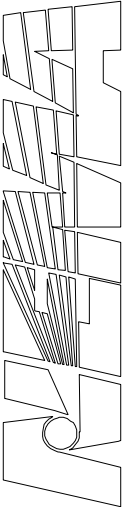
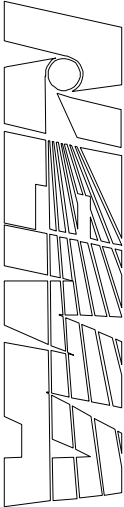
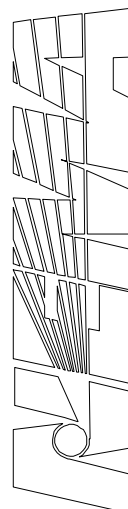
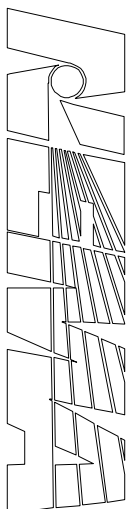

Figure A-6
“J” ROLLER

- 2) Semirigid and rigid—Semirigid polyvinyl acetate (PVAc) adhesives and rigid urea, resorcinol, and epoxy adhesives require pressure in a cold (room temperature) or hot press operation at approximately 275 kPa (40 psi) for an extended period of time. Semirigid adhesives are strong, colorless, provide ease of use, odorless, nontoxic, nonflammable, clean up with water, and catalyzed Type A versions are water resistant. Rigid adhesives are also strong and water resistant, but many are toxic and hard to clean up. Resorcinols are used in Class I(A) fire rated applications.

Proper adhesive spread and pressure should produce a small bead of adhesive flowing out all of the way around the edge of the glue line. A minimum of about 275 kPa (40 psi) is required and excessive pressure can result in a starved glue line or telegraphing of the substrate.

- d. Machining techniques—All chips, saw marks, and hairline cracks should be removed by filing, sanding, or routing as they will weaken the laminate and may lead to potential stress cracking problems at a later time. Saws and routers with carbide tipped blades are recommended to ensure chip free edges and prolonged tool life.
- e. Cutouts and inside corners—The inside corners of all cutouts for electrical outlets, ranges, sinks, grills, "L" shaped countertops, etc. must have a minimum radius of 3 mm (1/8 in.) or larger to reduce the possibility of stress cracking. A radiused corner created by a 6 mm (1/4 in.) diameter router bit is normally used. All edges and inside corners should be filed smooth and free of any chips or nicks.
- f. Waterproofing joints—Waterproof the backsplash seam areas on countertops which can be exposed to water or other fluids. A rabbet and groove construction with a waterproof adhesive or a receiving type molding with silicone caulking will provide satisfactory protection.
- g. Warpage reduction—Panel warpage can be reduced by acclimating the material, using the same laminate on both panel sides, aligning the sanding marks on both sides and using the same adhesive and application techniques on both sides. Thick cores resist warpage better than thinner cores. Paint, varnish, vinyl film, and fiber backers will not balance high-pressure decorative laminates. Spacing is required between panels to allow for movement.



A.6.2 Postforming Laminates

All forming materials have the same basic characteristics. However, each laminate supplier knows the inherent properties of their postforming-type laminate and should be consulted before starting.

Postforming laminates are made by incorporating modified thermosetting resins and by pressing techniques which allow the material to be thermally bent. The bend should be achieved quickly and uniformly when the proper temperature is reached. The reaction is final, and once bent the laminate cannot be reformed by reheating. Therefore, proper forming equipment and close attention to detail are recommended in this type of shop operation.

Some postforming fabricators maintain a list of each laminate by pattern along with the conditions of time and temperature which yield the most satisfactory results. Such data is most helpful when fabricators and laminate suppliers find it necessary to discuss technical problems.

Since countertops are secured to a framework, backer sheets are rarely used (see Figure A-7).

Installations which are exposed to higher than normal humidity conditions should have the sink cutout and all exposed wood sealed with paint, polyurethane varnish, or an appropriate backer sheet. Postformed cabinet doors (see Figure A-8) generally require a backer sheet or decorative laminate to minimize warpage. All materials should be properly conditioned, and all rules previously listed apply to this type of installation.

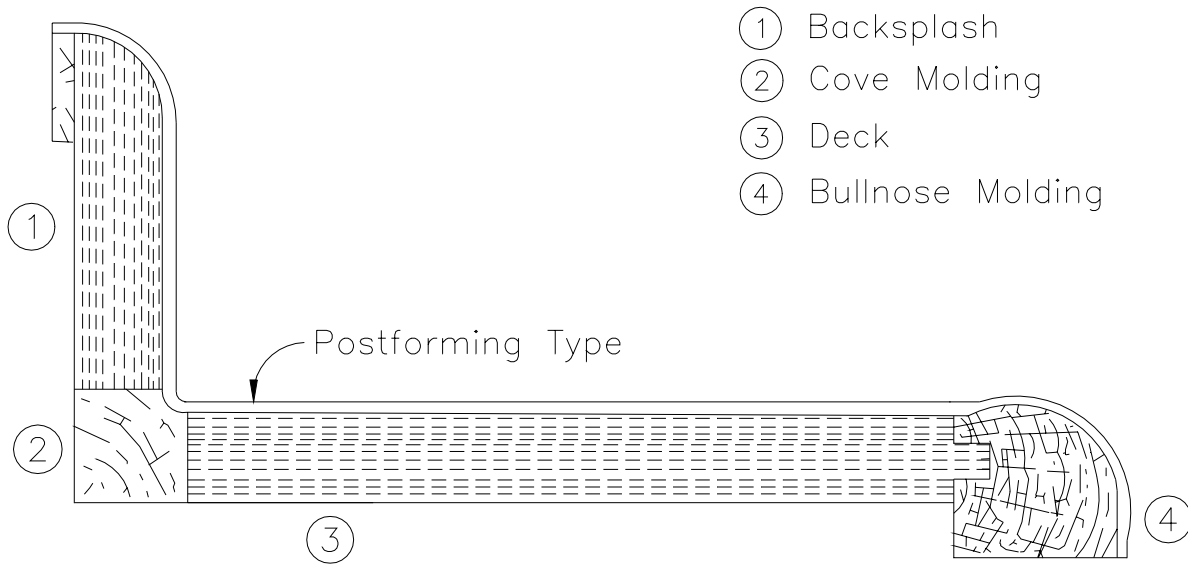

Figure A-7
TYPICAL POSTFORMED TOP

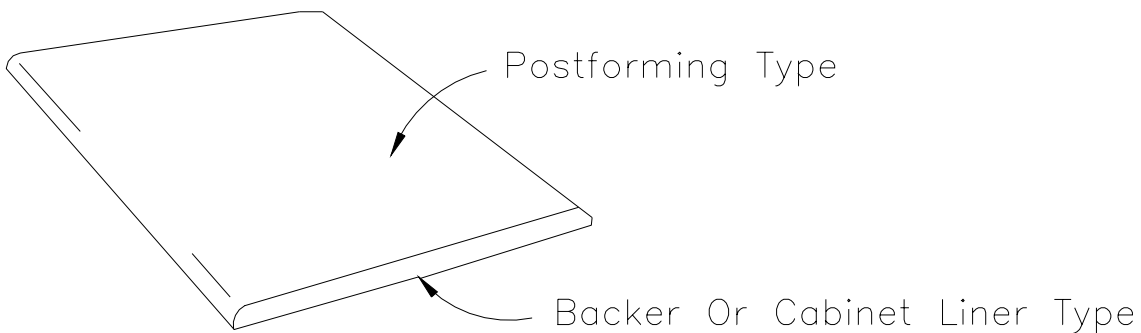

Figure A-8
CABINET DOOR

Bullnose, cove, and backsplash style moldings should have straight parallel surfaces so that the postforming material can be bent uniformly. Do not attempt to draw the laminate into compound radiused shapes.

A.6.3 Installation on the Job

Some major applications of laminates are in the construction of new buildings and the upgrading of old ones. As a final step before occupancy, counters which have been installed by the builder may be surfaced with laminates. Normally the material to be covered will be particleboard or plywood of good quality and should have a minimum number of seams. Contact adhesive should be used to bond the laminate to the substrate. On-the-job installation of laminates usually involves inside corners, outside corners, and cutouts. The fabricator is once again cautioned to observe all of the general rules listed in A.6 for working with laminates and should follow them implicitly. The importance of pressure when using

contact adhesives cannot be over emphasized. A pressure of 0.90 kg per linear millimeter (50 lb. per linear inch) should be used. Pinch rollers are not practical for on-the-job applications. However, a long handled rubber roller with a roll 50 to 75 mm (2 to 3 in.) in diameter and 75 mm (3 in.) wide, commonly called a "J" roller, can be used satisfactorily (see Figure A-6). Pressure should first be applied to the center of the sheet, working toward the edges to avoid trapping air which can cause surface bubbles, blisters, or cracking.

To sum up, on-the-job installations should provide for proper conditioning of the laminate, proper application of the adhesive, and close conformance with the general rules given in A.5 and A.6.

A.6.4 Field Working of Bonded Assemblies

Bonded decorative laminate assemblies may be sawed, routed, filed, drilled, and otherwise worked and fitted in the field. The tools used may be hand or power operated. Since decorative laminates may dull tools more rapidly than wood, it may be necessary to sharpen tools frequently as dull tools cause chipping. Carbide-tipped tools are recommended.

The following suggestions should be followed:

- a. Chamfer edges—Chamfer all exposed edges of decorative laminates by filing to prevent possible damage by chipping.
- b. Splines—When using splines, install them so that the tongue of the spline stays at least 1.6 mm (1/16 in.) away from the bottom of the groove. This should permit some movement and should tend to prevent warping in the event of panel movement.
- c. Seal edges—Seal exposed core edges by self-banding with laminate, with metal moldings, with waterproofing compounds, or by some other suitable means where they are exposed to water or high humidity. This is particularly applicable to joints in work tops, counters, bars, sink tops, baths, shower areas, and so forth.
- d. Cutouts—Avoid making cutouts in bonded assemblies where the entire core is cut away, thus leaving the laminate unsupported. Cutouts may be made, but some portion of the core material should remain as a support. In sawing angle cuts, such as in "L" shaped counters, care should be exercised so that the laminate is not undercut. All inside corners should be radiused to prevent stress cracking.
- e. Miter joints—Avoid making miter joints at 45° angles for outside corners of wall paneling, applied edges of tops, etc. A miter joint is particularly vulnerable to damage from sharp blows.
- f. Joining systems—Avoid using systems to join two or more sections of horizontal work surfaces which tend to weaken the structural rigidity of the joint. An example of a good system is the use of mechanical metal fasteners that permit accurate alignment and increase the strength at the joint.
- g. Inside corners—Avoid making cutouts having sharp corners and rough edges. All cutouts should be routed or filed to ensure smooth edges. A radius of 3.175 mm (1/8 in.) or larger in the corners is recommended to minimize stress cracking. The largest practical radius should be used.

A.7 TYPICAL PROBLEMS—CAUSES AND PREVENTION

Some problems which may arise after laminates have been fabricated and installed are:

- a. Stress cracking—Cracking of the laminate at corners and around cutouts (see Figure A-9) may be caused by improper conditioning, improper bonding, poor planning or any combination of these. Conditioning both the laminate and the substrate helps to prevent cracking caused by shrinkage. Rough edges, inside corners that have not been radiused, and forced fits can also cause cracking. Radiusing all edges and inside corners as large as possible 3 mm (1/8 in.) minimum will minimize stress cracking. A radiused corner created by a 6 mm (1/4 in.) diameter router bit is normally used. Seam placement of the laminate can also reduce stress cracking.

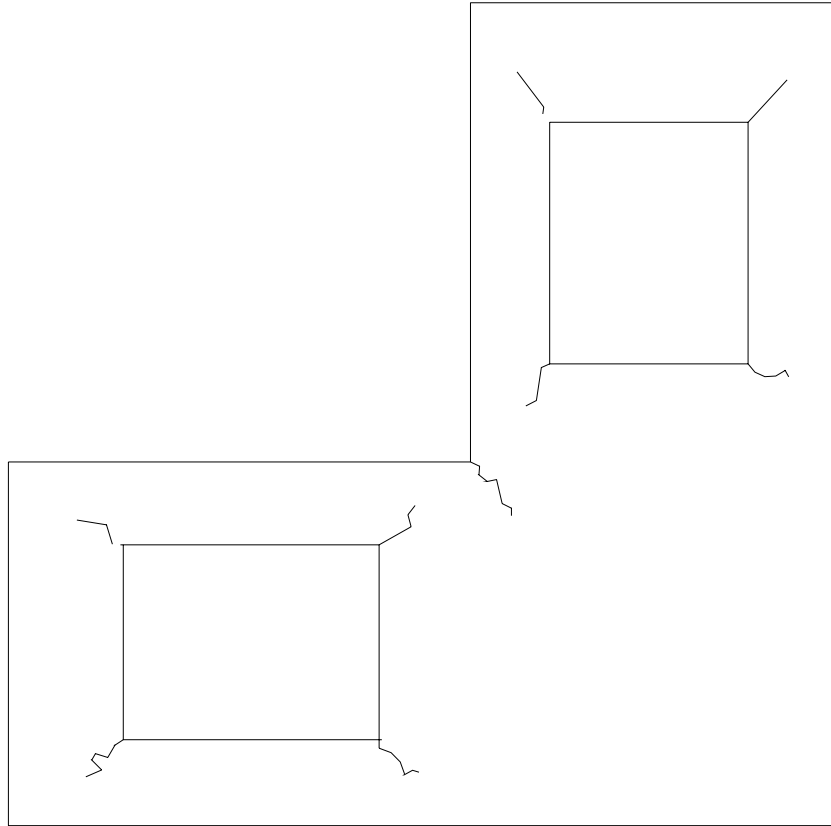

Figure A-9
CRACKING OF LAMINATE

- b. Open seams—Open joints or seams (see Figure A-10) are typically caused by improper conditioning and/or bonding. Conditioning both the laminate and the substrate helps prevent open seams caused by shrinkage. Allowance should also be made for some movement of the laminate.
- c. Glue line delamination—Separation of the laminate from the substrate (see Figure A-11) is generally caused by a poor adhesive bond. Factors that can influence the bond and cause poor adhesion are:
 - 1) Improperly prepared or dirty gluing surfaces
 - 2) Insufficient agitation or mixing of the adhesive
 - 3) Insufficient amount of adhesive on either or both surfaces
 - 4) Temperature of the gluing area and materials below 21°C (70°F)
 - 5) Blushing caused by excessive humidity
 - 6) Bonding when the adhesive coated surfaces are overdried or underdried
 - 7) Bonding with insufficient pressure
 - 8) Field bonding of oversize sheets

Contact adhesives can often be reactivated by heat and rebonded with proper pressure provided that adequate adhesive has been applied. In cases where the edge is lifting, extra adhesive may be added and the proper pressure applied.

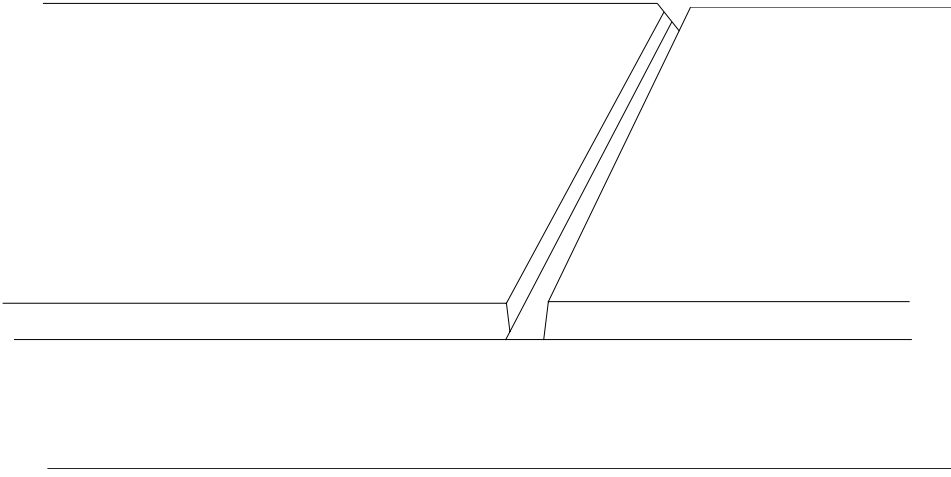

Figure A-10
OPENING OF JOINTS OR SEAMS

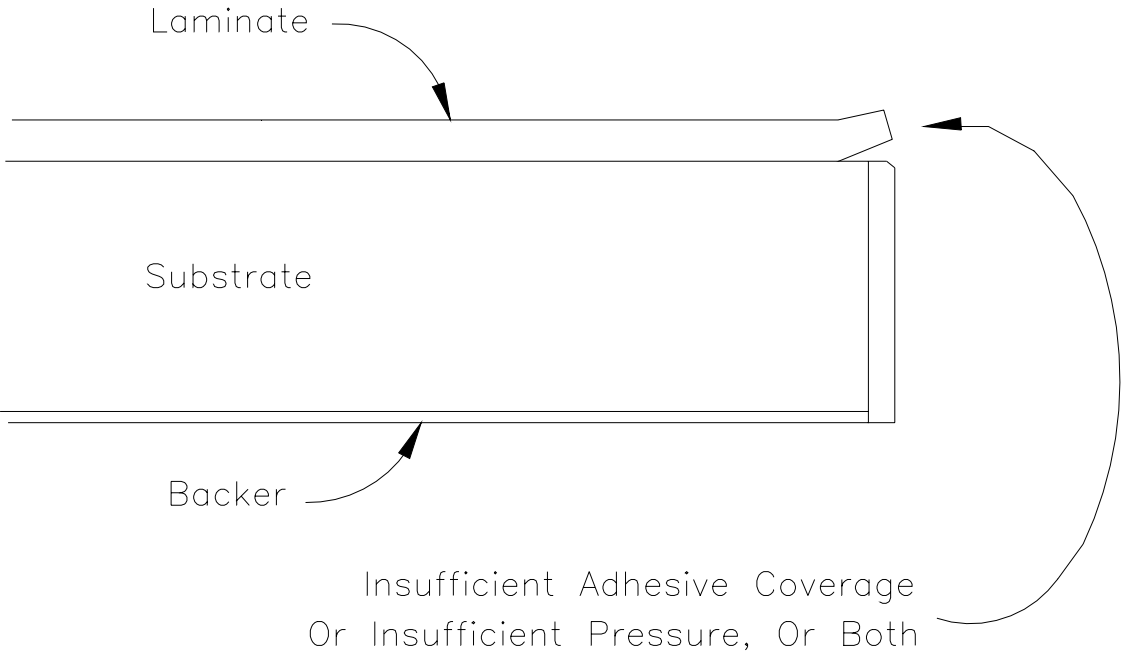
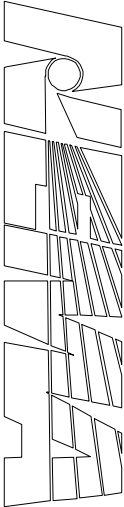

Figure A-11
SEPARATION OF THE LAMINATE FROM THE SUBSTRATE

- d. Blistering or bubbling caused by exposure to heat—The forming of a blister or bubble over a small well defined area, often accompanied by darkening of the laminate, can be caused by either a single or continual exposure to an outside source of heat. Appliances which produce heat, hot objects, light bulbs, etc. should not be placed in contact with or in close proximity to the laminate surface. Temperatures exceeding 66°C (150°F) may result in separation of the laminate from the substrate due to adhesive failure.

- e. Laminate cracking—Cracking in the center of the laminate sheet can be caused by flexing of the substrate when it spans a wide distance or by spot gluing. Wide spans require sturdy framework and all glue lines should be uniform. Avoid trapping foreign objects in the glue line between the laminate and the core as cracks will occur when pressure is applied.
- f. Panel warpage—Warping of the assembly (see Figure A-12) is generally attributed to the differences in dimensional change between the face and back laminates and the core or substrate material. Different adhesives or application techniques used on the front and back face can also cause panel warpage. When one side of a panel assembly is subjected to different humidity conditions than the other side warpage can result. Warpage can also result during hot pressing operations where the press platens have different temperatures. All panel components should be acclimated to the same environment prior to fabrication. Critical applications requiring a well balanced assembly should be constructed with the same laminate applied to both sides. Less critical applications may only require a cabinet liner or backer. Paint, varnish, vinyl film, and other coatings will not balance a panel having laminate on the other side. If the panel is secured to a framework, the framework should be designed and constructed to hold the assembly in a flat plane.

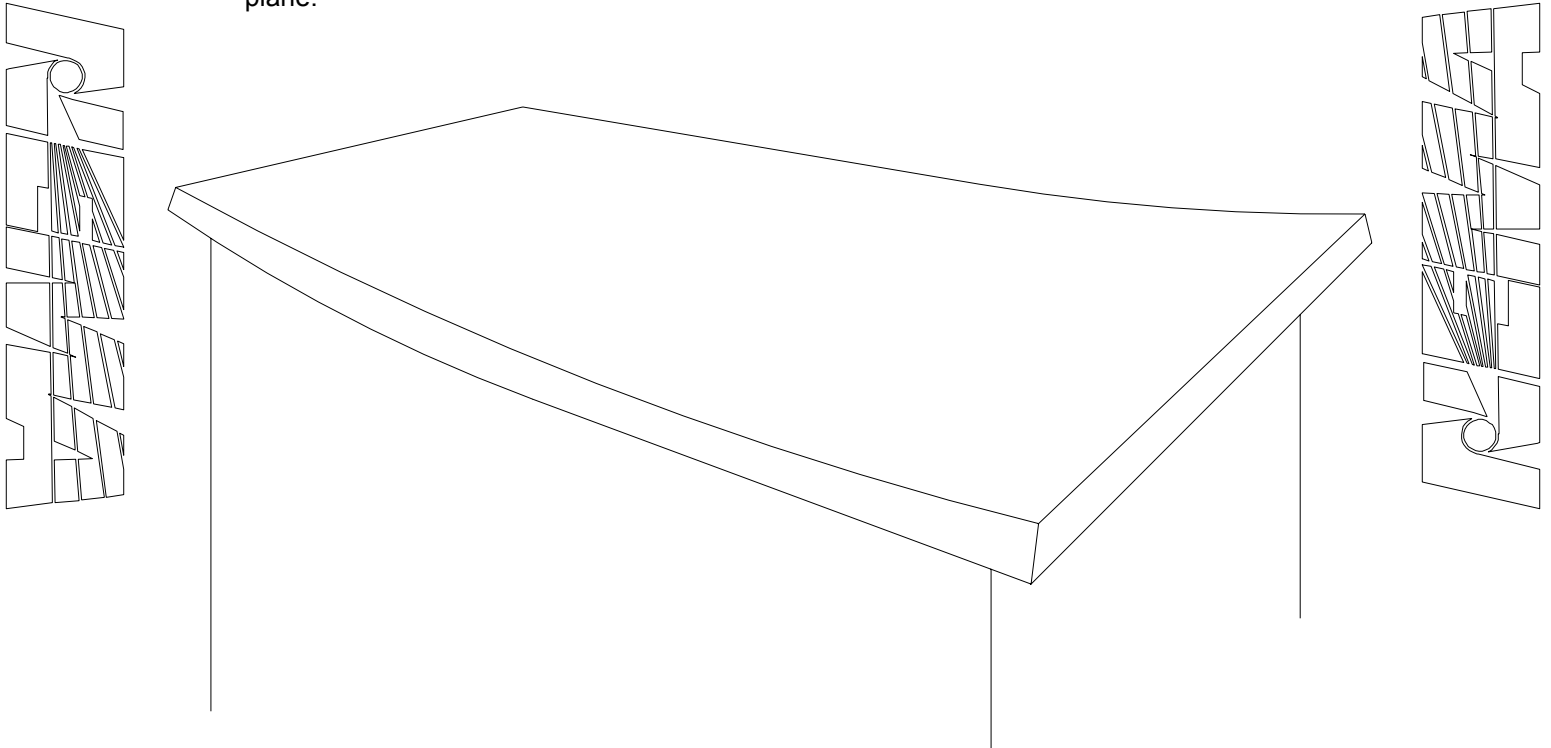

Figure A-12
LAMINATE WARPING